



CONTENTS

INTRODUCTION	1
RANGE OF PRODUCTS	
HD16 HEAVY DUTY ADJUSTABLE SELECTIVE PALLET RACKING SYSTEM	3
D-IN16 HEAVY DUTY DRIVE-IN PALLET RACKING SYSTEM	5
RSH16 HEAVY DUTY SHUTTLE RACKING SYSTEM	7
HDM16 HEAVY DUTY MOBILE RACKING SYSTEM	9
ASRS AUTOMATED MATERIAL HANDLING SYSTEMS	11
PB16 HEAVY DUTY PUSH-BACK PALLET RACKING SYSTEM	13
CANT16 CANTILEVER RACKING SYSTEM	15
MD16 MEDIUM DUTY ADJUSTABLE RACKING SYSTEM	17
LD16 LIGHT DUTY ADJUSTABLE SHELVING SYSTEM	19
LDLS16 LIGHT DUTY LONG SPAN ADJUSTABLE SHELVING SYSTEM	21
MMD16 MULTITIER MEDIUM DUTY RACKING SYSTEM	23
MLD16 MULTITIER LIGHT DUTY SHELVING SYSTEM	25
WIRE MESH DECKING PANELS	27
SOLID STEEL DECKING PANELS	28
CONVERTIBLE TIRE STEEL PALLETS	29
CONVERTIBLE STEEL PALLETS FOR FREEZERS AND TROLLIES	30
CUSTOMIZED FABRICATIONS AND PLASTIC BINS	31
POWER RACK FACTORY	32
CERTIFICATIONS	35



INTRODUCTION

Power Rack, headquartered in Bahra industrial area, KSA, is one of the leading companies providing integrated warehousing solutions and is a trusted partner in logistics industry. The company that started from humble beginnings since its inception in 2012 has grown to become one of the largest independent manufacturer and distributors of industrial storage systems including all related accessories and any equipment in storage and handling solutions. We are a proud member of the Electric House family of companies who's history stretches back 60 years to 1955. The Group's brand image diversified portfolio, market share as whole, infrastructure, financial strengths and confidence provides enchanting experiences to customers, vendors, and employees.

Our consultative and integrated solutions approach along with quality products we offer have made the company known and recognized highly by all its customers for exceptional quality assurance, innovative ideas, outstanding products and excellence in customer service. The one element that runs consistent throughout all our companies is that we continuously strive for the best quality in everything we do and we always improve and develop ourselves.

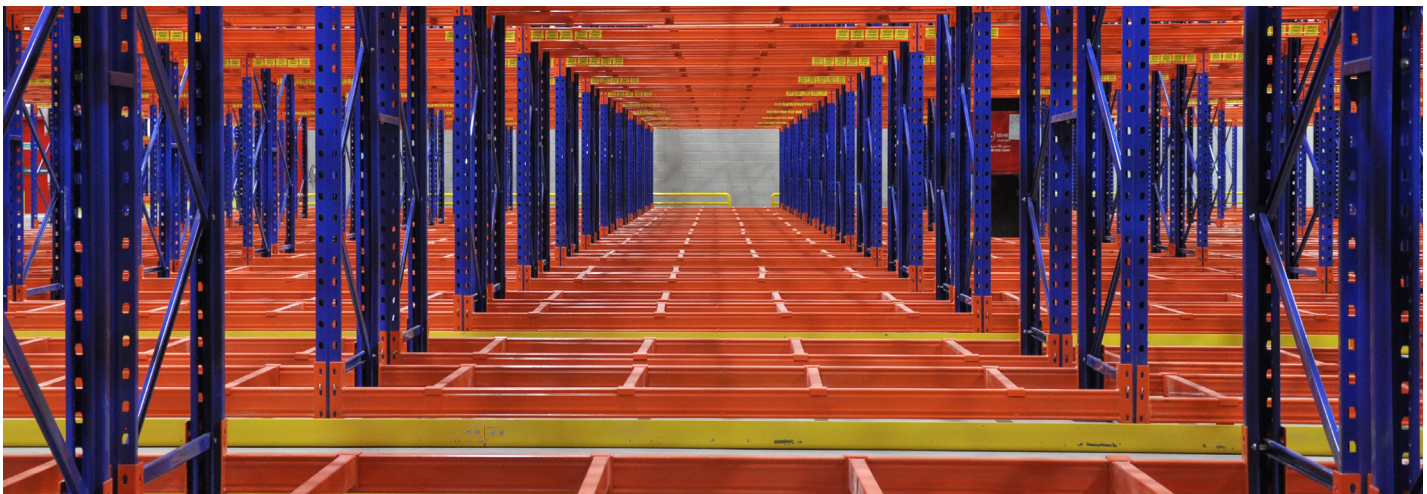

POWER RACK FACTORY

Manufactures high quality Storage Systems, custom made steel fabricated items and related accessories. State-of art Factory adhering to International Standards ISO 9001: 2015 and TÜV SÜD. The storage system complies with EN15512, FEM & SEMA standards. All the products in Power Rack have been studied and tested by TÜV SÜD and a conformity certificate and test certificates have been issued.

Power Rack covers the main markets of GCC, Africa & MENA Region. The company serves the needs of many industrial sectors engaged in the field of:

Manufacturing industries, E-commerce industry, Freight forwarders, Third party logistics, Cargo and Courier companies, airports, sea ports, dry ports, FMCG's, Pharmaceuticals, Distribution Centers, Retail and Automotive, Hospitality Industry, Banks, Contractors, Furniture & Interior Design, Government Departments, Medical Centers and Hospitals, Oilfield Petroleum, Supermarket, Shopping Malls, and many more.

Our highly experienced and skilled staff will be delighted to consult and cater your business needs.

Please call us for free consultation on your storage and handling operations!



RANGE OF PRODUCTS

SPR AND VNA PALLET RACKING SYSTEM

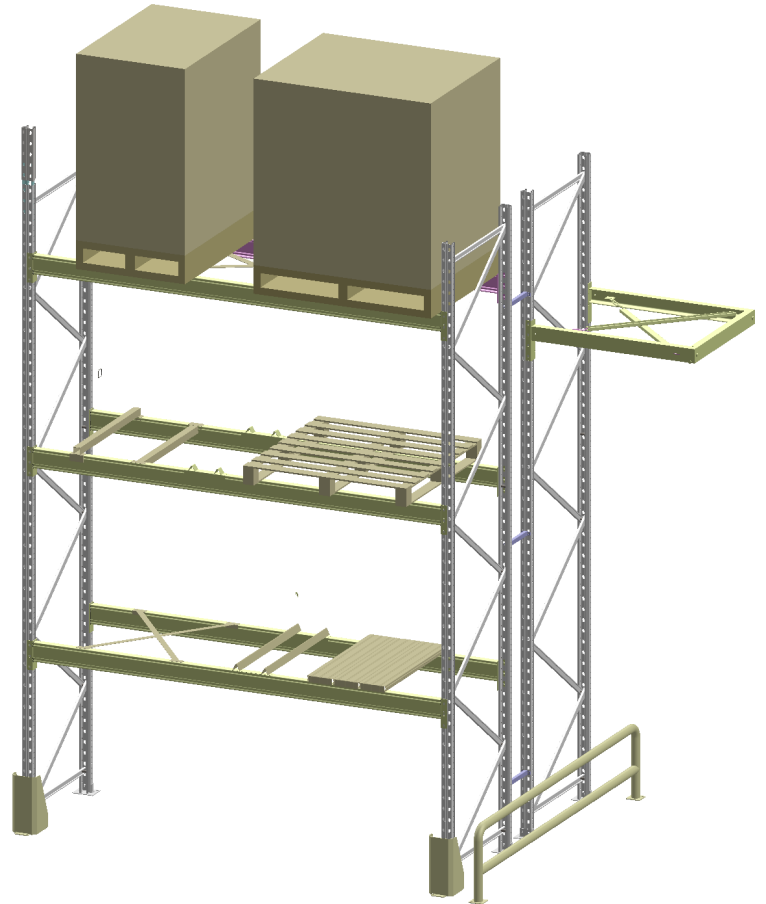

SPR - Selective Pallet Racking system provides 100% selectivity and access to all SKU. Modular adjustable system, suitable for various storage operations and accessible with almost all kinds of material handling equipment's. SPR is the most standard system used worldwide in vast majority of storage applications with possibilities of many optional accessories.

Beam section

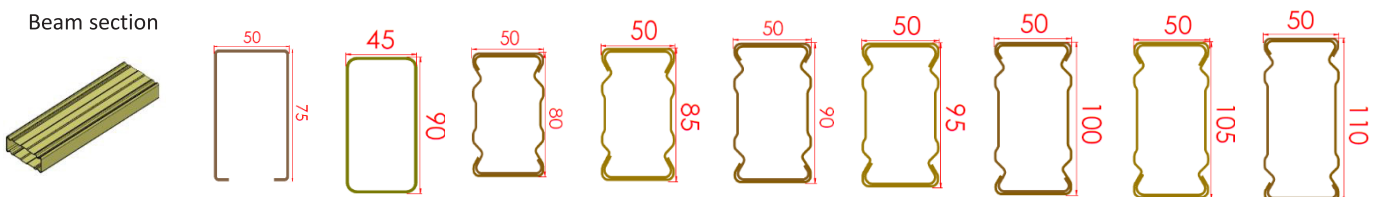

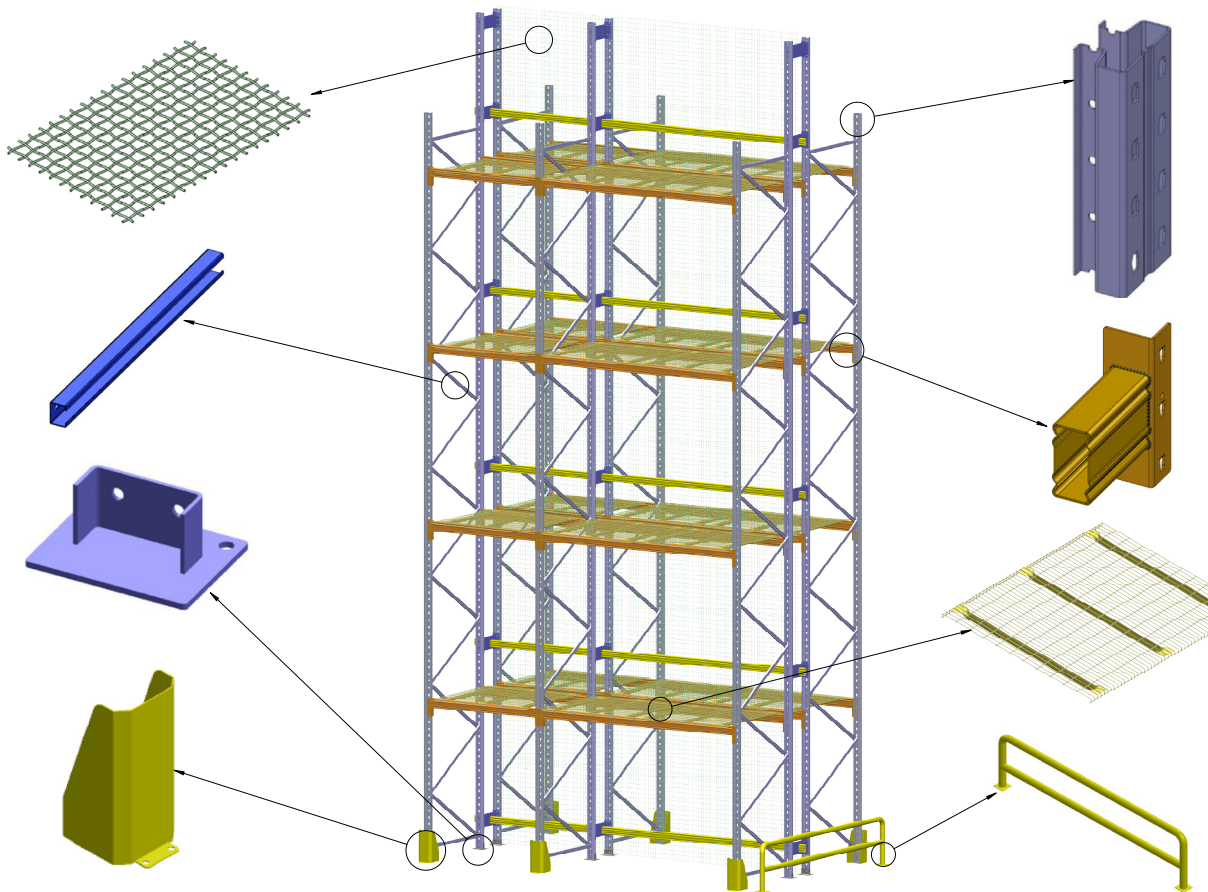

VNA - Very Narrow Aisle Pallet Racking system also provides 100% selectivity dense storage with increased footprint by applying Narrow aisle access. High Rise VNA storage system is also one of the key advantages aimed by many customers due to faster operational efficiency with guided drive system. Customer achieve higher outputs with safe movements. System can also be designed for order picking needs along with pallet replenishment. Equipment used is VNA & order pickers. Ideal for 3PL, freight forwarders, manufacturing, and many other applications.

Beam section

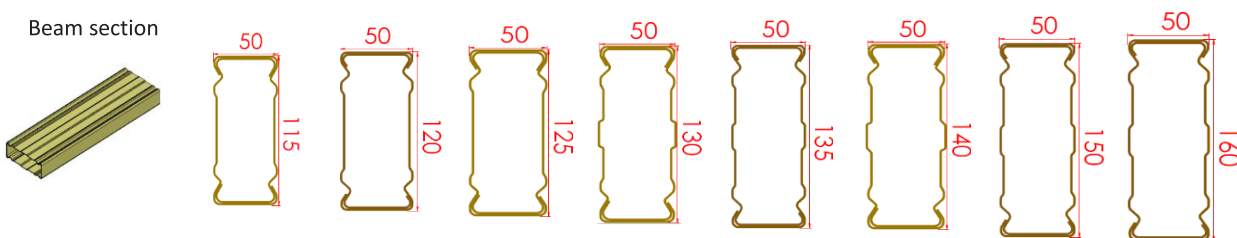

DRIVE-IN PALLET RACKING SYSTEM

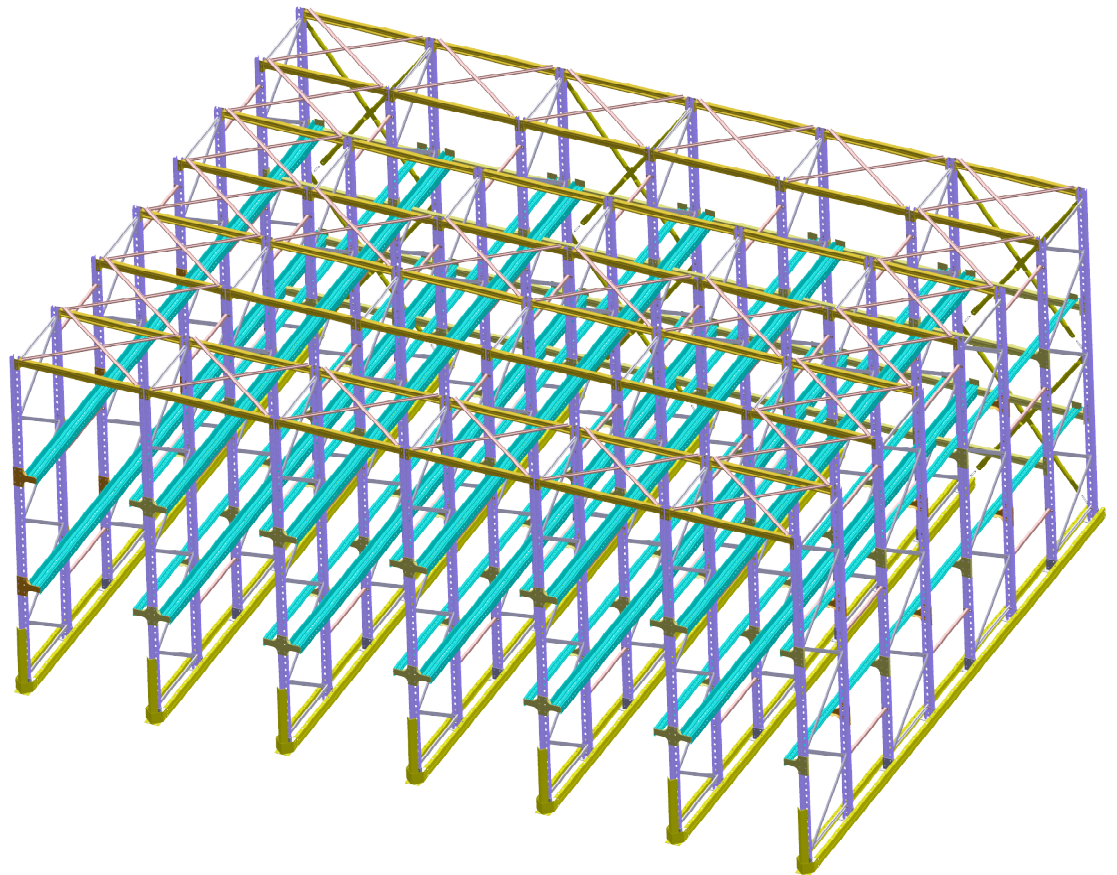

Drive in / Drive Through - Drive in Pallet Racking provides very compact storage by eliminating maneuvering aisles and optimizes more than 75% of the available area. Very limited selectivity enable systems to be used for large SKU of same articles and can be designed as *FIFO or *LIFO. Ideal for Cold storage and temperature controlled warehouse operations where energy savings are vital. MHE used are ECB, special Reach trucks.

*FIFO: First in first out.

*LIFO: Last in first out.



SHUTTLE PALLET RACKING SYSTEM

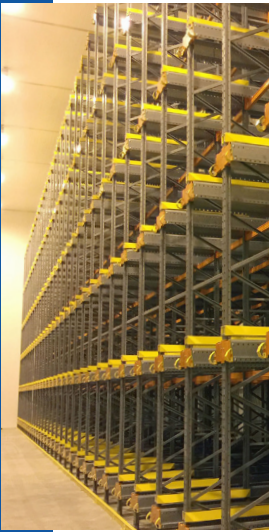

Pallet Shuttle Racking - Advanced version of drive in system where a pallet shuttle cart drives in the racks instead of MHE providing faster operation times and highly reduce the chances of in rack accidents with less pickers. Semi-automated system also provides better storage allocation of each deep location compared to full lane dedication in drive in system. System enables users to modernize their operations with high throughput efficiency along with much reduced racking maintenance costs. Shuttle system can be used for multiple shifts with spare batteries and also helps in stock keeping. System can be programmed as FIFO or LIFO and provides quick ROI.



MOBILE RACKING SYSTEM



Mobile Racking System - Semi automated, dense storage system with almost 100% selectivity. System works on motorized and guided mobile base system on rails. With all safety features in action, system provides higher space utilization by elimination multiple aisles. Accessed by remote controls and provides night mode for better cooling circulation. ECB, Reach Trucks and stackers can be used. Ideal solution for cold stores and freezers where aim is to maximize energy utilization.



AUTOMATED MATERIAL HANDLING SYSTEMS

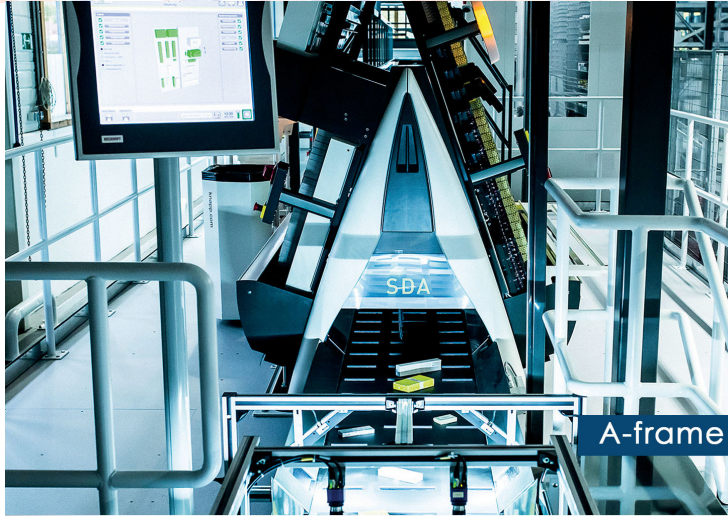

A-frame

In partnership with



ALS
LOGISTIC
SOLUTIONS

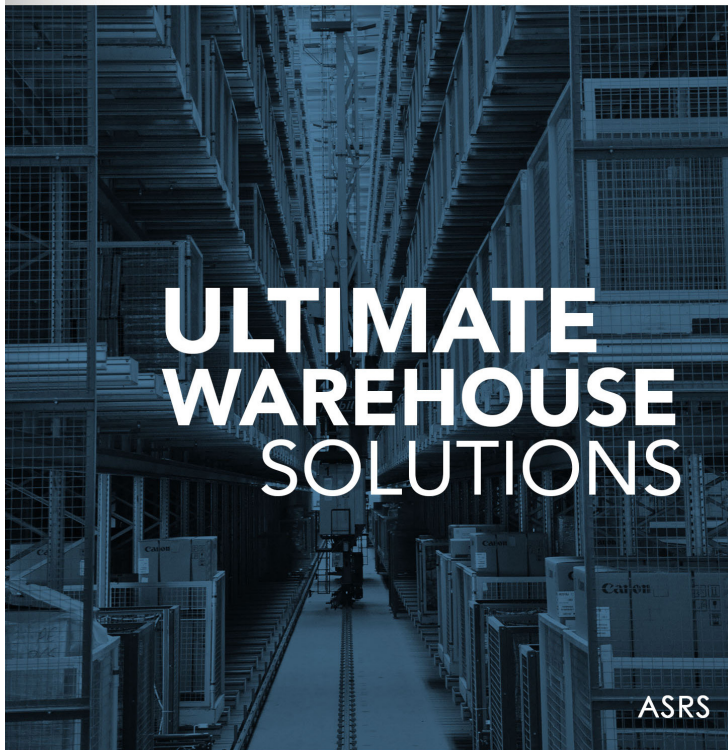

ULTIMATE WAREHOUSE SOLUTIONS

ASRS



Shuttle



Pharma Store



Work Station

Pick-it-Easy

In partnership with



ALS
LOGISTIC
SOLUTIONS

Micro Fulfillment Center



AGV Forklift



Monorails/Linear Handling Solutions



Conveyors/Sorters



PUSH-BACK PALLET RACKING SYSTEM

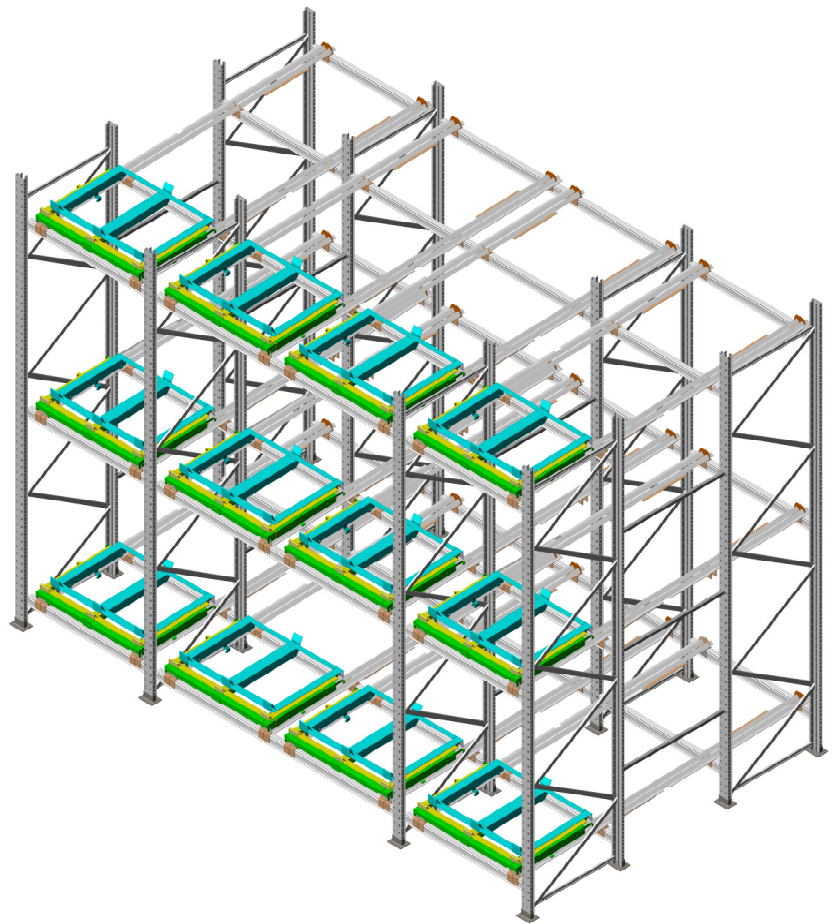

Push Back Racking System - is ideal for medium rotation SKU's with single loading/unloading point from the front and works on *LIFO principle. Loading operation is achieved by applying force on the pallet and moving to rear end of the system. Unloading happens with gravity flow. Used mostly in dispatch or collection areas with limitation of 6 deep maximum.

*Last in First Out.

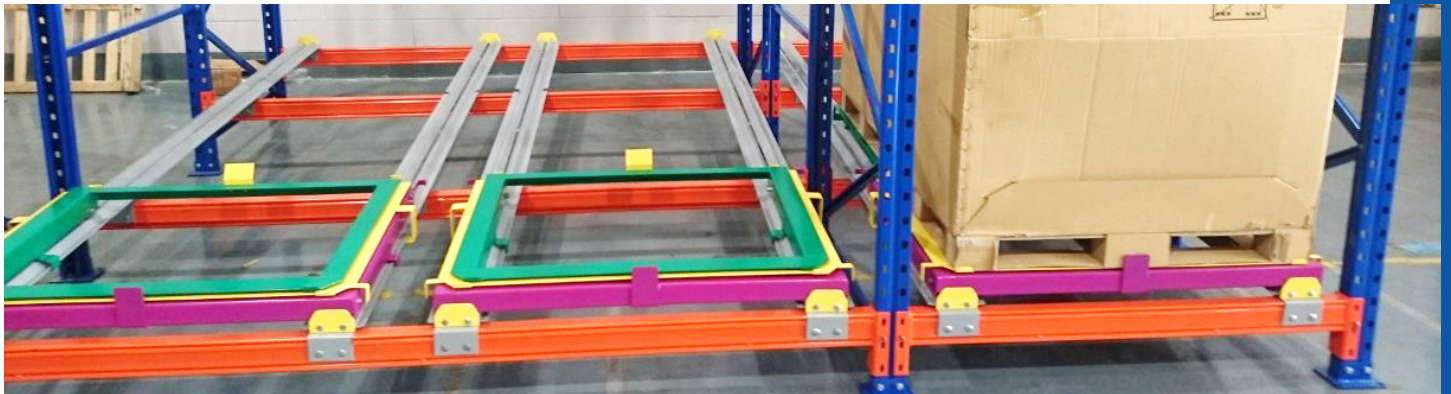
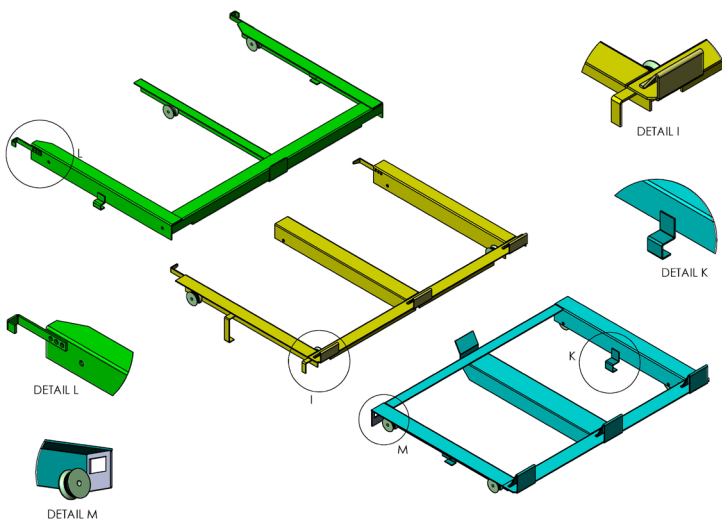

CANTILEVER RACKING SYSTEM

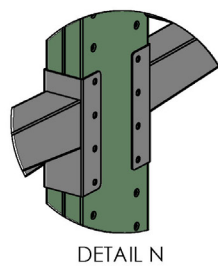

DETAIL N

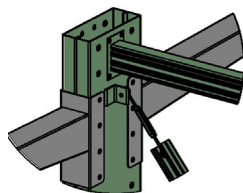

DETAIL L

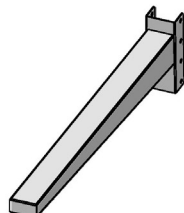

DETAIL ARM

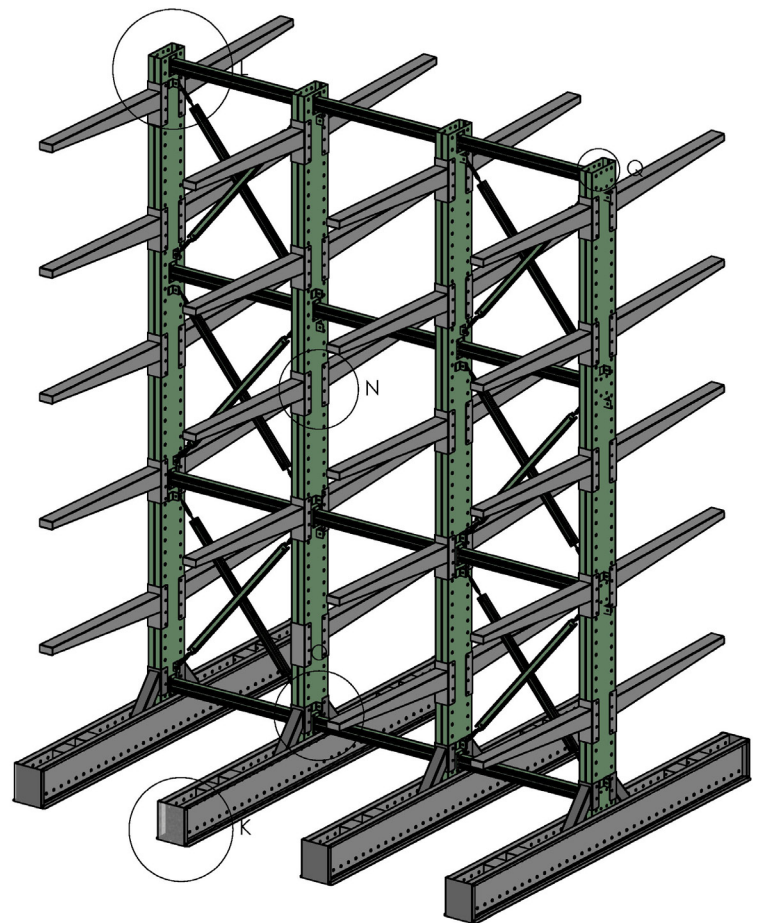

Cantilever Racking System - Specifically designed for storage of items with larger lengths like beams, pipes, metal profiles, wood, carpets, textiles, etc. System is built using strong base, vertical columns and unique cantilever arms. Loading can be done via various lifting systems like cranes, side loaders and standard MHE's.

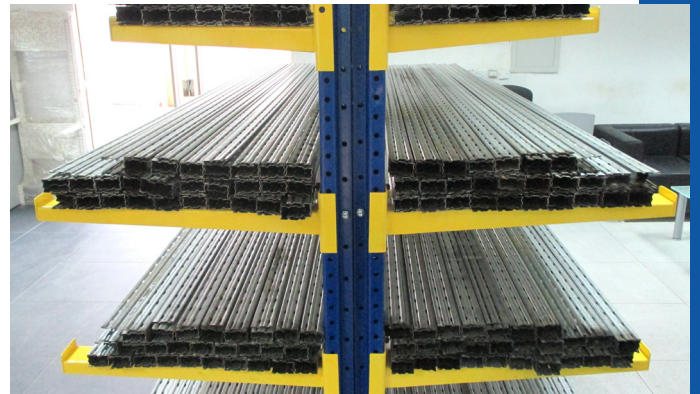
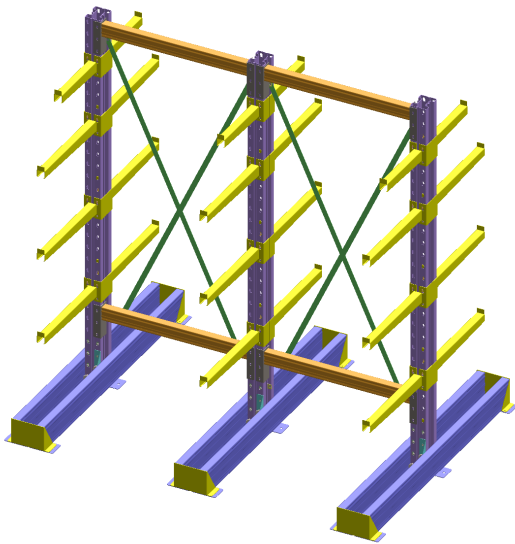

MEDIUM DUTY SHELVING SYSTEM

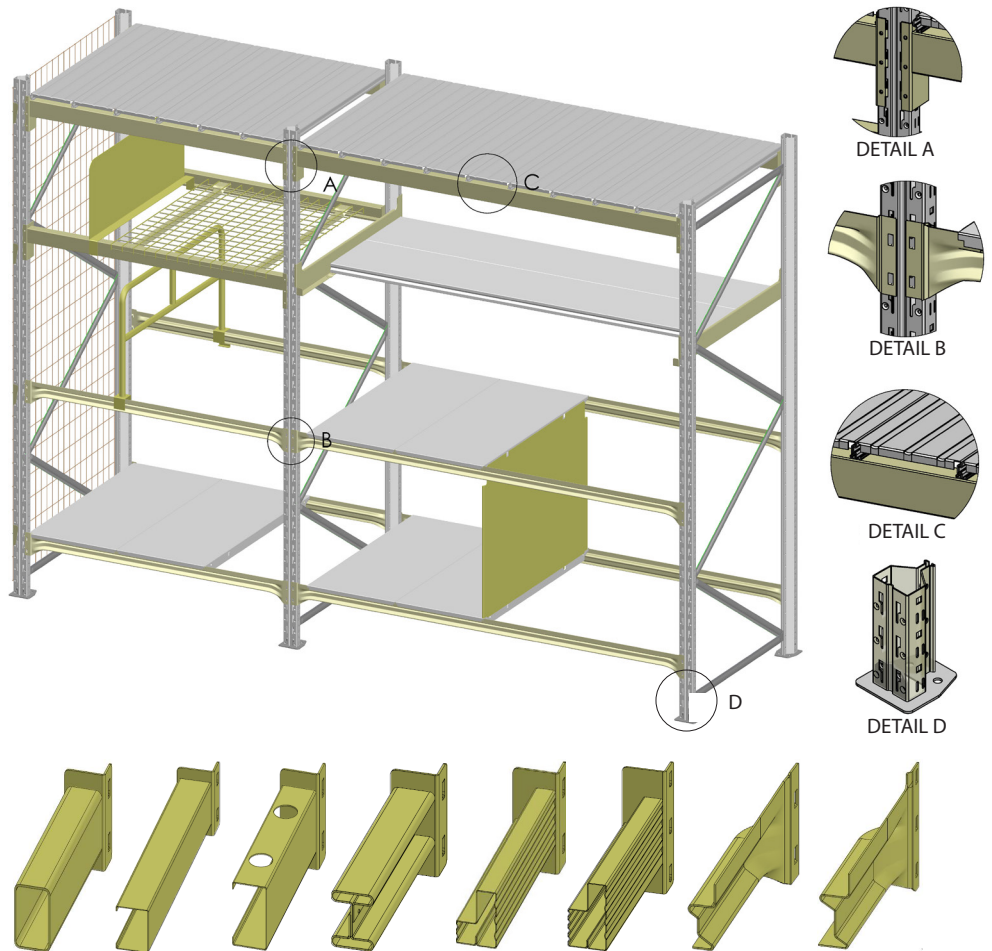

Medium Duty Shelving System - traditional shelving system used for storage and picking of light and medium duty products like plastic bins, cartoon, boxes, parts, merchandising, supermarkets, archiving, back stores, etc. It provides wide range of accessories with versatility to suit various businesses. Bolt free shelving system easy to assemble and adjust. Multi-tier system can be used for optimizing height and meeting fulfillment centers demands.



LIGHT DUTY SHELVING SYSTEM

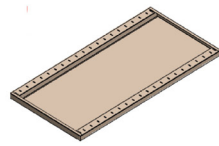

Shelf without Stiffener

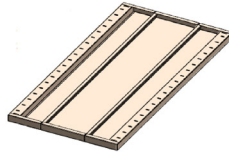

Shelf with Stiffeners

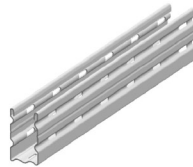

Upright

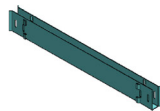

Brace



Back Bracing Clamp



Walkway Clamp



Hook Zink Plated

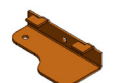

Back Panel Clamp



Light Duty Shelving System - traditional shelving system used for storage and picking of light and medium duty products like plastic bins, cartoon, boxes, parts, merchandising, supermarkets, archiving, back stores, etc. It provides wide range of accessories with versatility to suit various businesses. Bolt free shelving system easy to assemble and adjust. Multi-tier system can be used for optimizing height and meeting fulfillment centers demands.



LIGHT DUTY LONG SPAN SHELVING SYSTEM

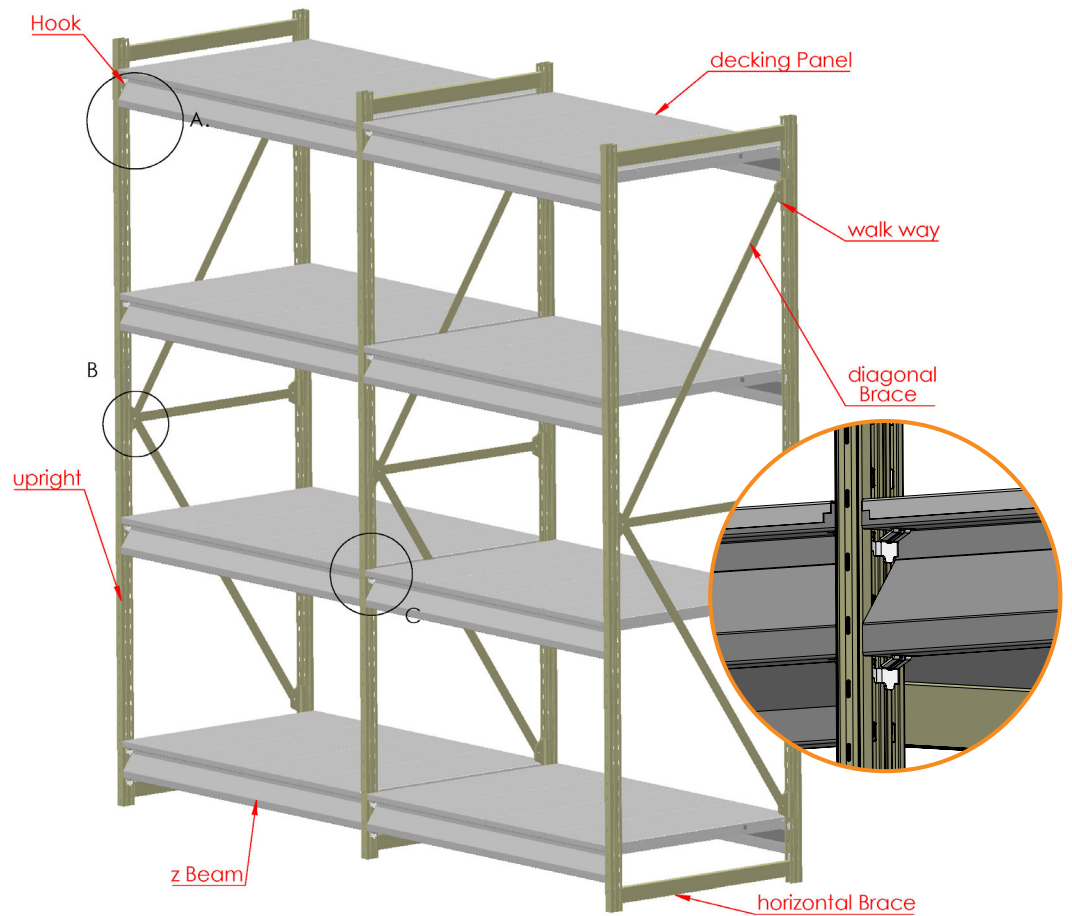

Light Duty Long Span Shelving System - traditional shelving system used for storage and picking of light and medium duty products like plastic bins, carton, boxes, parts, merchandising, supermarkets, archiving, back stores, etc. It provides wide range of accessories with versatility to suit various businesses. Bolt free shelving system easy to assemble and adjust. Multi-tier system can be used for optimizing height and meeting fulfillment centers demands.



MULTITIER MEDIUM DUTY RACKING SYSTEM

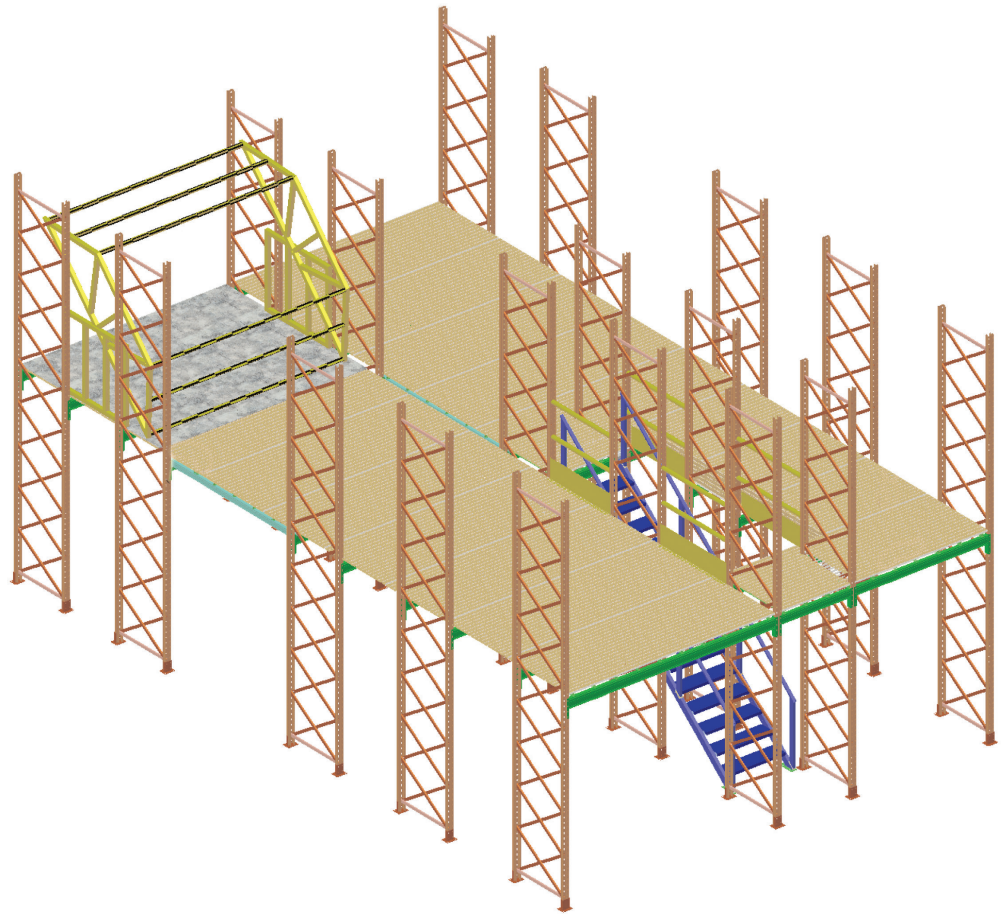

Multitier Medium Duty Racking System - Used frequently for order picking of medium to heavy SKU's. System can be equipped with various decking options like solid / wire mesh decking panels. High rise system can be used in combination with order pickers for height utilization.

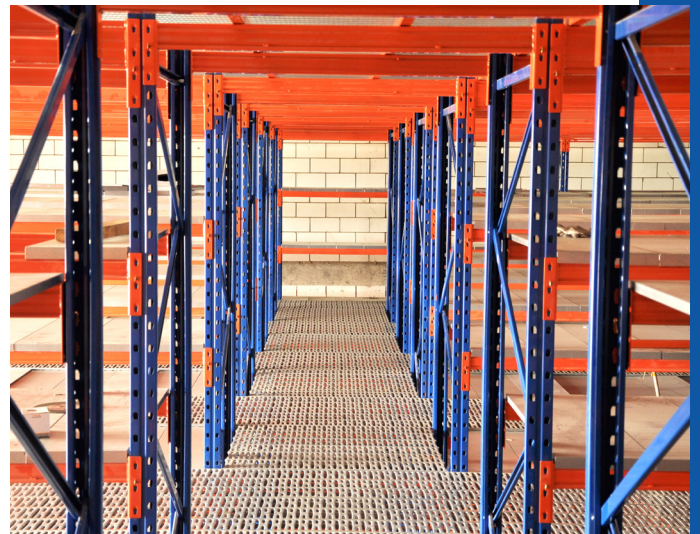

MULTITIER LIGHT DUTY SHELVING SYSTEM

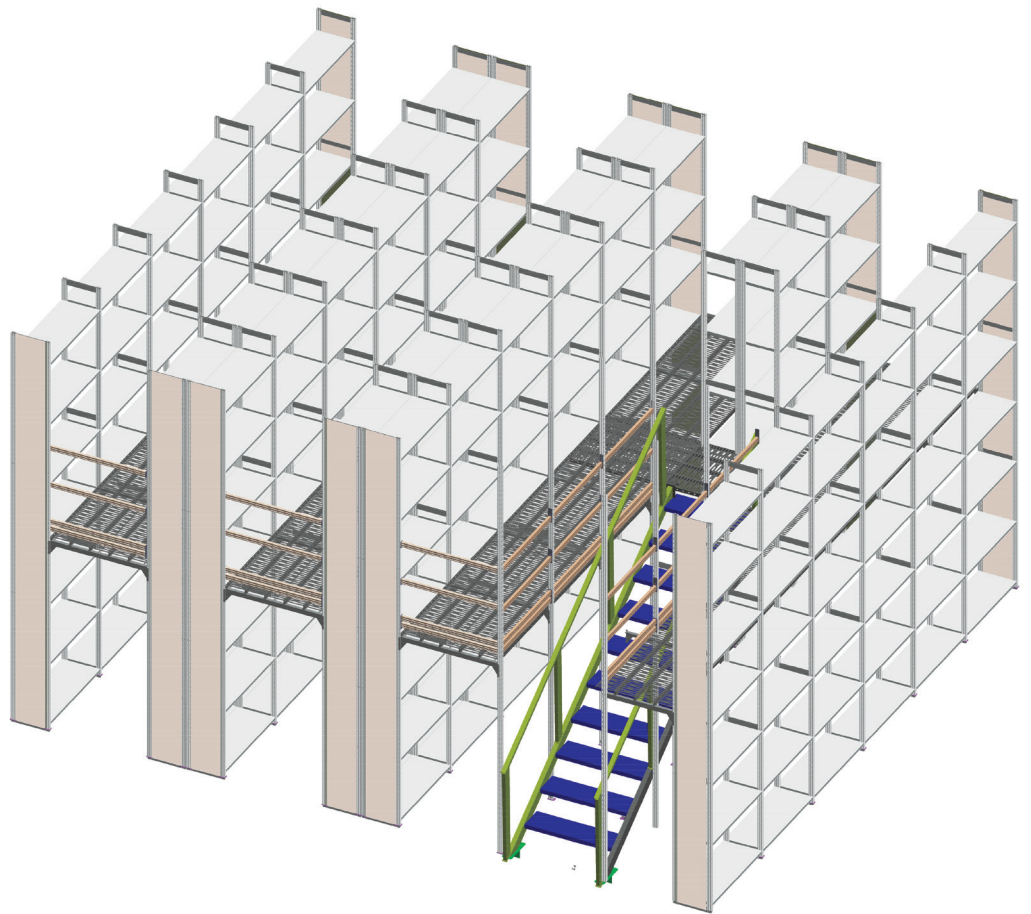

Multitier Light Duty Shelving System - Used frequently for order picking of light to medium SKU's. System can be equipped with various decking options like solid / wire mesh decking panels. High rise system can be used in combination with order pickers for height utilization.



ACCESSORIES

WIRE MESH DECKING PANELS

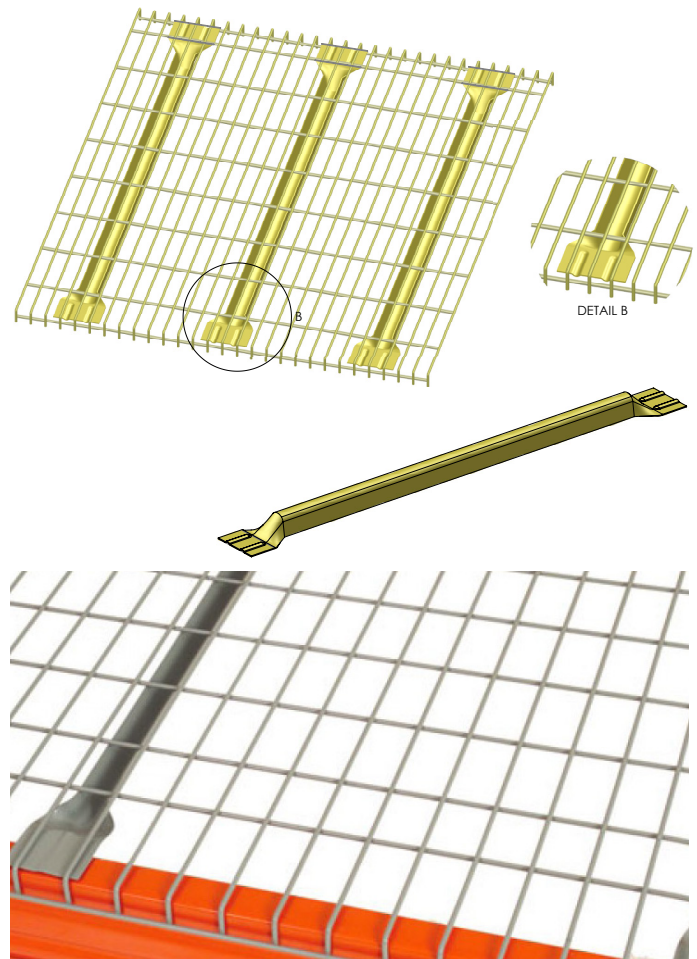

Wire Mesh Decking Panels - Widely used in storage system and available in various sizes. Special hot dip galvanized finish available. Wire Mesh can also be provided for side and back cladding.

SOLID STEEL DECKING PANELS

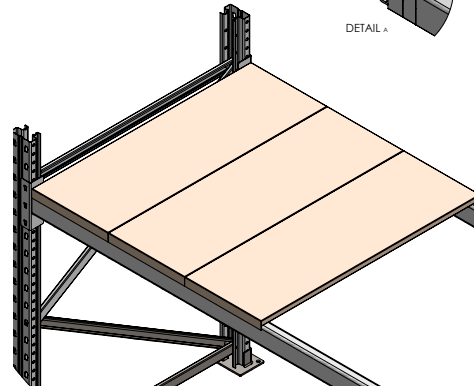
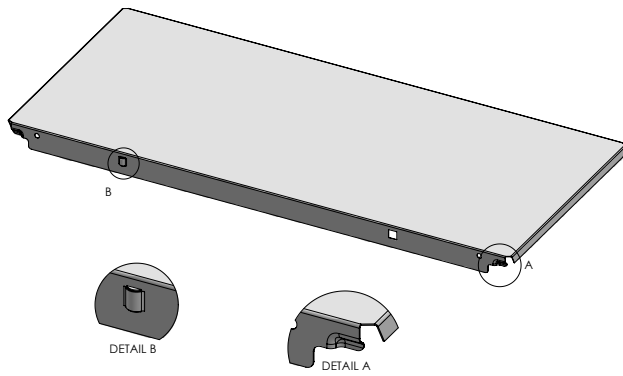
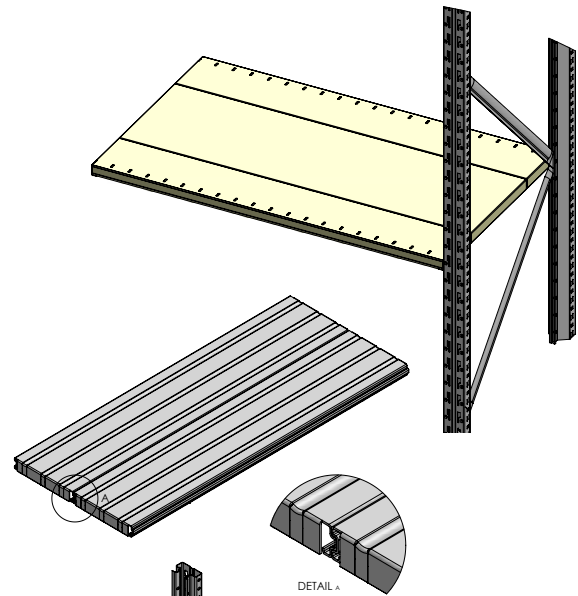

Solid Steel Decking Panels - Widely used in storage system and available in various sizes. Supplied in pre-galvanized or power coated finish. Customized perforations possible.

CONVERTIBLE TYRE STEEL PALLET

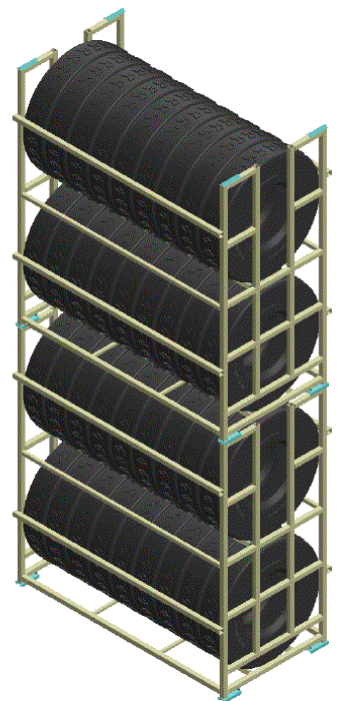
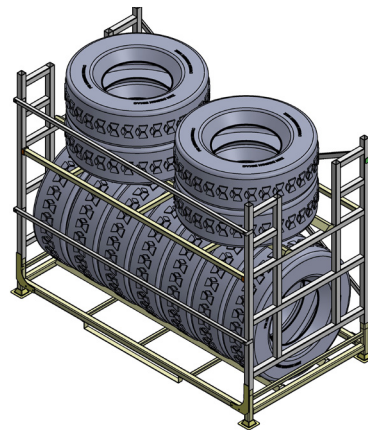
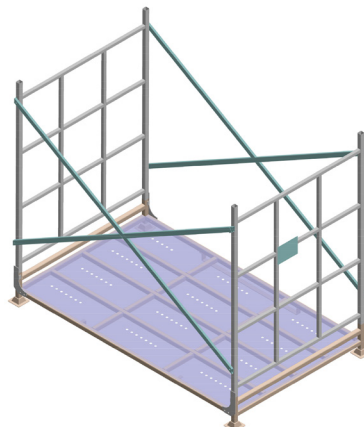

Convertible Tyre Steel Pallets - Produced and designed for any kind of tires (Passenger cars and Trucks). Available in hot-dip galvanized or powder coating.

CONVERTIBLE STEEL PALLETS FOR FREEZERS

Convertible Steel Pallets - Produced and designed for various type of storage requirements. Available in hot-dip galvanized or powder coating. Can be used with wooden/plastic pallets as well.

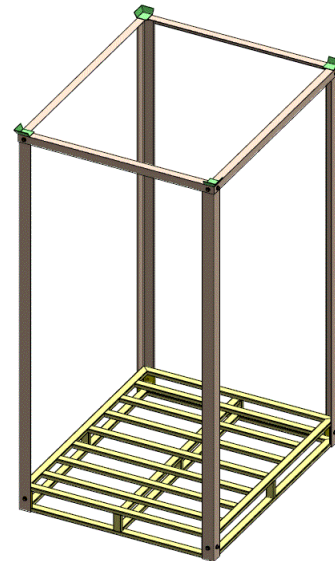

PICKING TROLLEYS AND CAGES

Picking Trolleys and Cages - Tailor made based on customer requirements. Used in customized and wide range of industries.

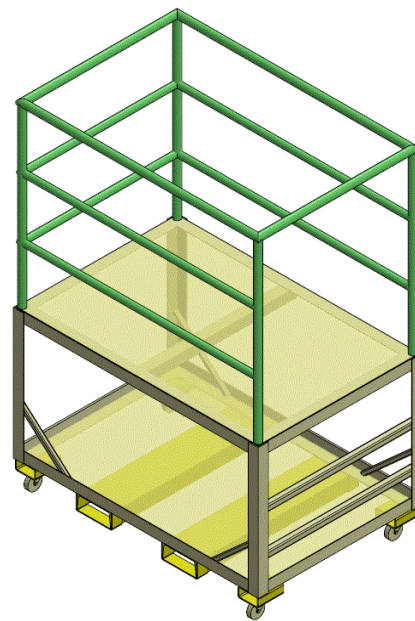
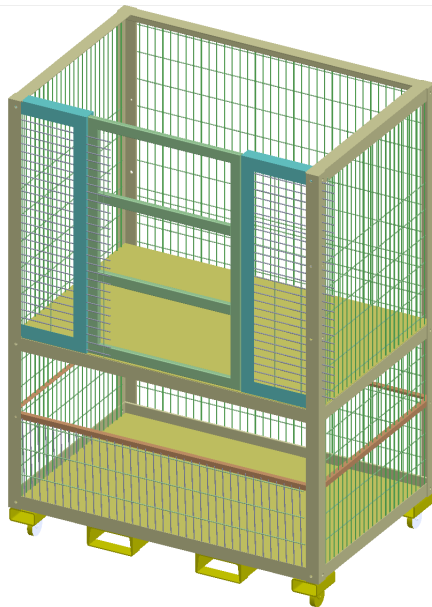

CUSTOMIZED FABRICATIONS

Customized Fabrications - All kind of customized fabrications can be furnished at our start of art manufacturing facility. Please get in touch with our sales consultants for any special requirements.



PLASTIC BINS

Plastic Bins - Used in vast range of industries for storage and picking requirements. Available in various sizes and options.



FACTORY





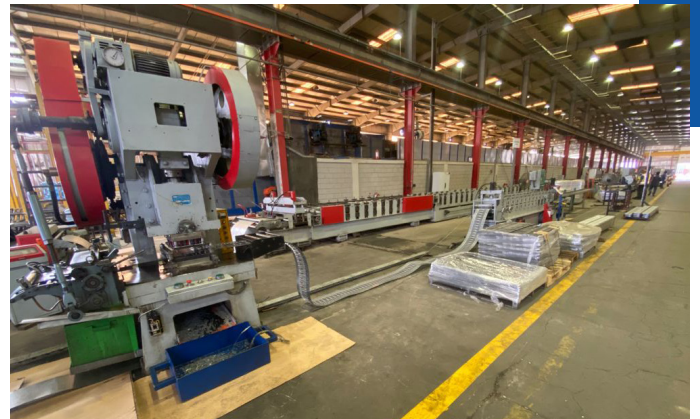
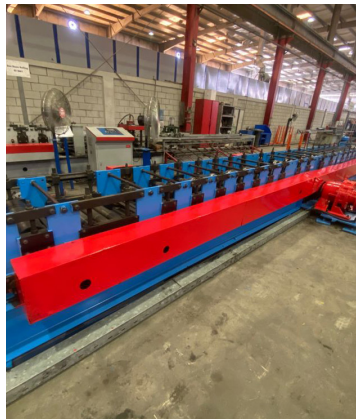
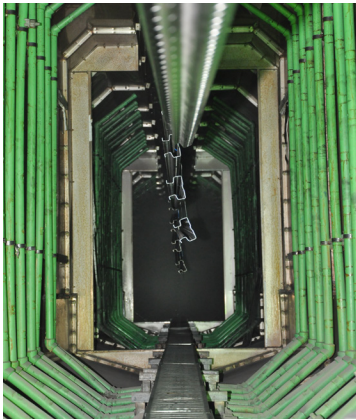
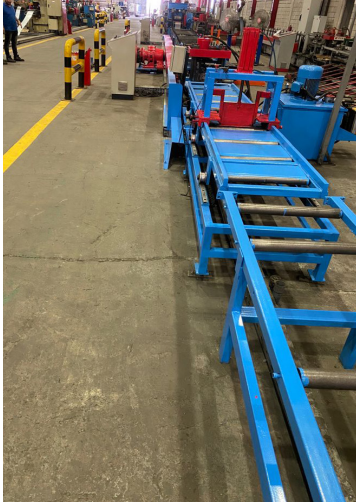

CERTIFICATE

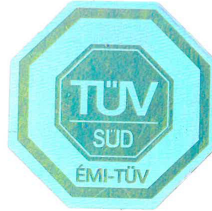

ÉMI-TÜV SÜD

Quality Assurance and Safety Technique Ltd.
(2000 Szentendre, Dózsa György st. 26. - Hungary)

as a certification body operating in accordance with
MSZ EN ISO/IEC 17065:2013

by the request of

POWER RACK FACTORY
(Kingdom of Saudi Arabia, P.O. Box #11967 Jeddah - 21463)

on the basis of the result of the certification procedure

certifies that the

Heavy Duty Pallet Racking System

designed and manufactured by Power Rack Factory

conforms to the requirements of the standard

EN 15512:2009

**„Steel static storage systems. Adjustable pallet racking systems. Principles
for structural design”**

and

S.E.M.A. “Code of practice for the design of static racking”

Number of the certificate: T-41078/2016-T

The certification is valid until 29/06/2021 or until any change in the relevant standard or code.
Valid together with the report no. T-41078/16 only.

Budapest, 30th of June, 2016



Attila Várdai
certification expert

TUV®



American Systems Registrar, LLC, a provider of third-party system registration and accredited by the ANSI National Accreditation Board attests that:

POWER RACK FACTORY

RING ROAD, MAKKAH EXPRESS WAY; CPC INDUSTRIAL PARK, MAKKAH HIGHWAY
BAHRA, KINGDOM OF SAUDI ARABIA

with a scope of:

DESIGN, MANUFACTURING & SALES OF STEEL RACK STORAGE SYSTEMS

has established a quality management system that is in conformance with the International Quality System Standard

ISO 9001:2015

ASR Certificate Number: 6173
Date of Certification: March 8, 2021
Date of Certification Expiration: March 7, 2024
Date of Initial Registration: July 12, 2015
Revision:
Re-Issue Date:



Richelle Kingie
President

CERTIFICATE OF REGISTRATION



**Endorsement
Renewal – New Schedule**

CGL & Product Liability Policy No. 1/22/2/2016

Office: Jeddah

Endorsement No.15/2021

It is noted and agreed that this policy is renewed for a new period; the schedule and specifications of the original policy are amended to read as stated herein.

The Insured

Power Rack Factory

The nature of the Insured's business or operations in respect of which the Policy is effected

Storage Trading & leasing out of Handing Equipment

Period of Insurance

From 28/02/2021 To 27/02/2022
Both days inclusive

Territorial Limits

Saudi Arabia, GCC, Middle East and Africa

Jurisdiction

Saudi Arabia

The indemnity granted by the policy is to apply for

In respect of Insured's liability at law for accidental damage to third party property and/or accidental bodily injury to third parties and arising out of the insured's activities. (including product liability)

The amount of indemnity shall not exceed

- a. in respect of any one accident or series of accidents arising out of one event
- b. in the aggregate in respect of all accidents occurring during any one period of insurance

USD 1,000,000

USD 1,000,000

Deductible

SAR 10,000 Each and every loss

Conditions, Clauses & Warranties

Sr. No.	Description
1	Information Technology Hazards Exclusion - Liability
2	Terrorism Exclusion Endorsement
3	Excluding professional Liability
4	Excluding political risk , wars , sabotage
5	Sanction & Embargos Clause.

Signed by the Insured

Signed on behalf of the Insurance Company
in Jeddah on 07/03/2020



1

التاريخ ١٤٤٢/١٢/١٦
الموافق ٢٠٢١/٠٧/٢٦
رمز الشهادة ٣٩٩٤٤٠٨٧



شهادة

إسم المنشأة : شركة مصنع رفوف الطاقة
ص.ب : ٢١٤٦٣ جدة ١١٩٦٧
السعودية
رقم الإشتراك : ٥٠٨٥٨١١٣٠
رقم السجل التجاري: ٤٠٣٠٢٤٤٩٠١

مصدره : جدة

رقما	كتابة	عدد المشتركين السعوديين
٣٤	أربعة و ثلاثون مشتركا	عدد المشتركين غير السعوديين
٨٧	سبعة و ثمانون مشتركا	المجموع
١٢١	مائة و واحد و عشرون مشتركا	

تشهد المؤسسة العامة للتأمينات الإجتماعية بأن المنشأة المذكورة أعلاه قد أوفت بالتزاماتها تجاه المؤسسة وفق البيانات المقدمة منها حتى تاريخ إصدار هذه الشهادة ، والتي تم منحها لتقديمها لأية جهة تطلبها ، وهي صالحة لجميع الأغراض التي نص عليها نظام التأمينات الإجتماعية في المادة (٦/١٩) منه.
هذه الشهادة سارية المفعول حتى ١٤٤٣/٠١/١٦ هـ.

يلزم التحقق من صحة وصلاحيه الشهادة عبر زيارة الرابط
أدناه في الموقع الإلكتروني للمؤسسة العامة للتأمينات الإجتماعية
أو عن طريق استخدام
الرمز المعرف التالي :



www.gosi.gov.sa/vc

(الشهادة معتمدة من صاحب الصلاحيه ولا تحتاج إلى توقيع أو ختم)

ننهادة

www.gosi.gov.sa
800 1243344



تعد هذه الشهادة من الوثائق الإلكترونية الحكومية الرسمية ، ويحظر قطعيا تقليدها أو إدخال أي تعديلات عليها سواء بالإضافة أو الحذف أو التغيير في بياناتها أو غير ذلك من أنواع التعديل ، وتعد الشهادة لاغية إذا شابهها شيء من ذلك ، كما تعرض صاحبها للملاحقة النظامية أمام الجهات المختصة بالإضافة إلى مايفرضه نظام التأمينات الإجتماعية من عقوبات ، ولايجوز تداول الشهادة إلا في الأغراض التي أصدرت لأجلها وفقا لأحكام نظام التأمينات الإجتماعية ، والمؤسسة العامة للتأمينات الإجتماعية غير مسؤولة عن أي آثار أخرى مترتبة قبل الغير عن الشهادة وغير مسؤولة عن أي عملية تزوير أو تعديل تتم على البيانات الواردة فيها .

التأمينات الإلكترونية
بإمكانك من مكانك

شهادة سعودة

تاريخ الإصدار : ١٤٤٢/١١/١٩
تاريخ صلاحية الشهادة : ١٤٤٣/٠٢/٢٢
رقم الشهادة : ٢٠٠٠٢١٠٦٠٠٣٢٨٤

اسم المنشأة: شركة مصنع رفوف الطاقة

رقم الملف: ١٠٩٨.٨٥-٩

سجل تجاري: ٤.٣.٢٤٤٩.١

الصادر من: جدة

تشهد وزارة العمل والتنمية الاجتماعية بأن المنشأة المذكورة أعلاه حققت نسب التوطين المطلوبة منها..
وتم منحها هذه الشهادة حسب طلبها
(الشهادة معتمدة من صاحب الصلاحية ولا تحتاج إلى توقيع أو ختم)

تنبيهات:

١ - يمكن التحقق من صحة وصلاحية الشهادة عبر زيارة الرابط:

٢ - في حال اكتشاف أي عملية تزوير في الشهادة المقدمة نرجو التبليغ عن ذلك بخطاب رسمي لأقرب مكتب عمل.

CERTIFICATES



تاريخ الترخيص : ١٤٣٩/٠٢/٢٤ هـ
الرقم المميز : ٣١٠٠٩٧٥٠٧٦



الهيئة العامة للزكاة والدخل
GENERAL AUTHORITY OF ZAKAT & TAX

المملكة العربية السعودية
الهيئة العامة للزكاة والدخل
GENERAL AUTHORITY OF ZAKAT & TAX
(١٨٥)

شهادة CERTIFICATE

شهادة تسجيل في ضريبة القيمة المضافة VAT registration certificate

تشهد الهيئة العامة للزكاة والدخل بأن المكلف : شركة مصنع رفوف الطاقة
مسجل في ضريبة القيمة المضافة بتاريخ : ١٤٣٩/٠٢/٢٤ هـ ، وتحمل الرقم الضريبي : ٣١٠٠٩٧٥٠٧٦٠٠٠٠٣

عنوان المركز الرئيسي :
المدينة : الحي :
صندوق البريد : الرمز البريدي :
الهاتف : ٠٠٩٦٦٥٠٠٤٧٩٧٧٦

الهيئة العامة للزكاة والدخل



هذه الوثيقة مرسله من النظام الآلي ولا تحتاج إلى توقيع

LOCATION MAP

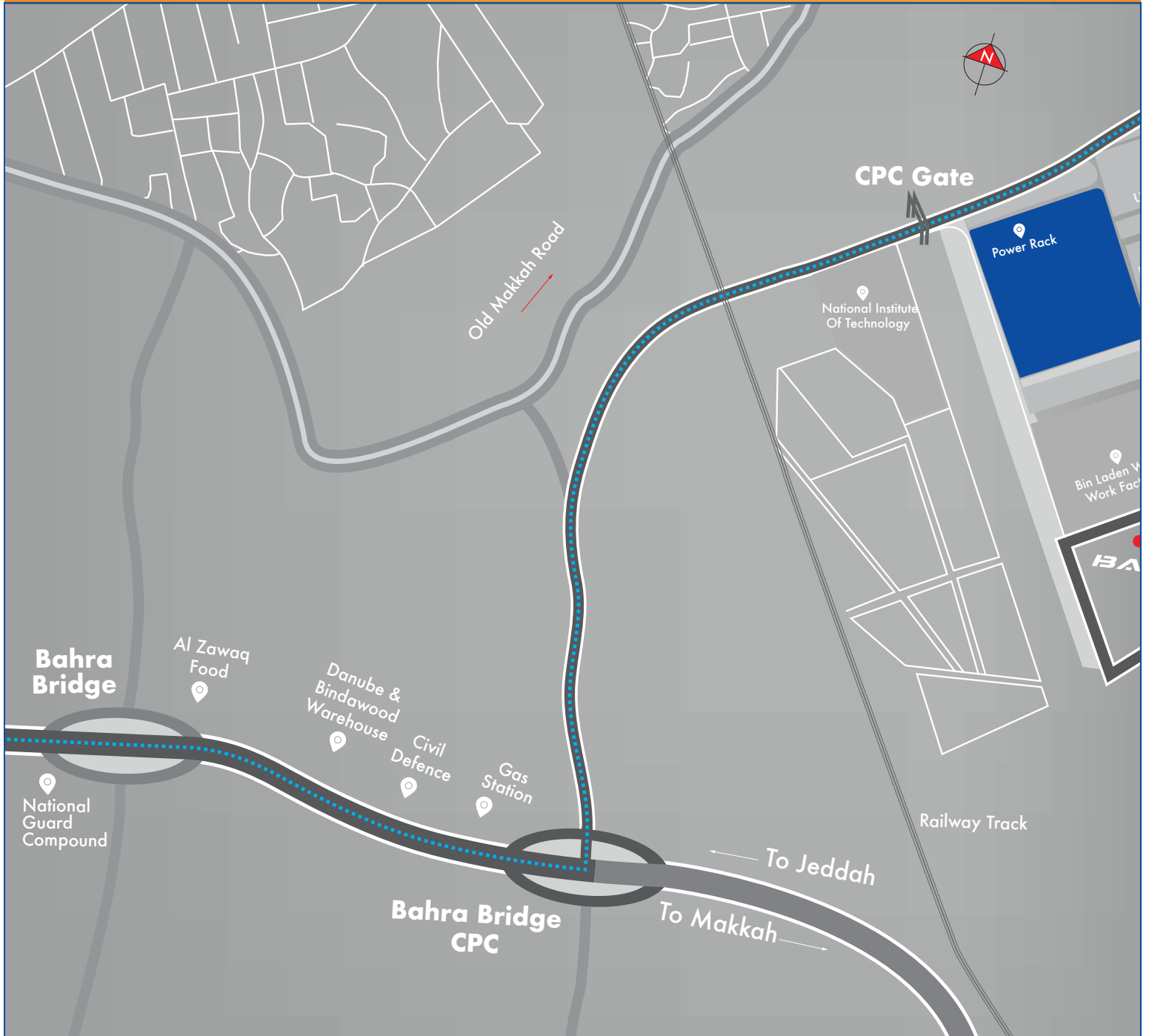

GPS Cordinates
21°24'35.38"N
39°30'48.19"E



Scan for the
Location